

# OWNER'S MANUAL

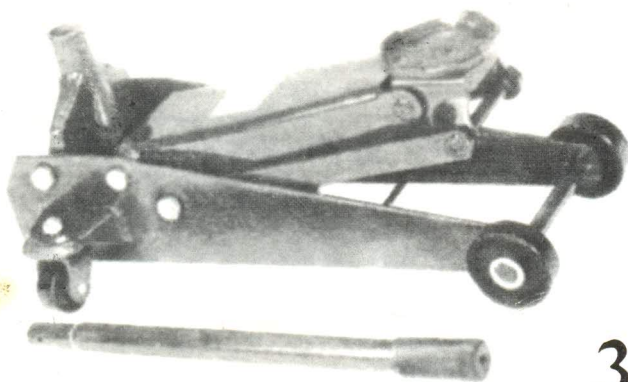

**3 TON**



**CAUTION: Carefully Read Instructions and  
Procedures for Safe Operation**

## Important Information

### WARNING

- This jack is a lifting device designed ONLY for lifting part of the total vehicle (i.e., one wheel). Do not move or dolly the vehicle while it is on the jack.
- Position this jack to ONLY lift on the areas of the vehicle as specified by the vehicle manufacturer.
- After lifting the vehicle, ALWAYS support the load with appropriately rated vehicle support stands BEFFORE working on the vehicle.
- Do not overload this jack beyond its rated capacity. Overloading can cause damage to or failure of the jack.
- This jack is designed ONLY for use on hard level surfaces capable of sustaining the load. Use on other than hard level surfaces can result in jack instability and possible loss of load.
- Center load on jack saddle BEFFORE lifting vehicle. Off-center loads and loads lifted when the jack is not level can cause loss of load or damage to the jack.
- Study, understand and follow all instructions in this manual BEFFORE operating the jack.
- Failure to heed these warnings may result in loss of load, damage to the jack and/or jack failure resulting in personal injury or property damage.
- Never use speedy lift device to raise load.

### OPERATING PRINDIPLES

#### With release valve CLOSED:

- An upward stroke of the jack handle draws oil from the reservoir tank into the plunger cavity. Hydraulic pressure holds the valve closed, which keeps the oil in the plunger cavity.
- A downward stroke of the jack handles release oil into the cylinder, which forces the ram out. This raises the saddle. (NOTE: Raises if the load exceeds the rated capacity, oil is automatically released back into the reservoir through the safety overload valve.)
- When the ram reaches maximum extension, oil is bypassed back into the reservoir to prevent an overextended ram stroke and possible damage to the jack.
- Opening the release valve allows oil to flow back into the reservoir. This releases **hydraulic pressure** on the ram, which results in lowering the saddle.

## OPERATION

### RAISING the jack:

- Close release valve by turning the handle clockwise.
- Block the vehicle's wheels for lifting stability.
- Refer to the vehicle manufacturer owners manual to locate approved lifting points on the vehicle. Position jack so that the saddle (see Fig.1) is centered under the load at an appropriate lift point.
- Pump jack handle or speedy lift lever until saddle NEARS contact with the vehicle. Check to see that the saddle is centered and will contact the load lifting point firmly.
- Continue to pump the jack handle to lift the vehicle to the desired height. After lifting, support the load with appropriately rated vehicle support stands **BEFORE** working on the vehicle.
- No person should remain in a vehicle that is being jacked.

### MAINTAINING OIL LEVEL

Important Note: When adding or replacing oil, **ALWAYS** use good grade hydraulic jack oil. **DO NOT** use Hydraulic Brake Fluid, Alcohol, Glycerin, Detergent Motor Oil or dirty oil. Use of an improper fluid can cause serious internal damage to your jack.

Note: Before initial operation lubricate the jack as indicated in Fig 1

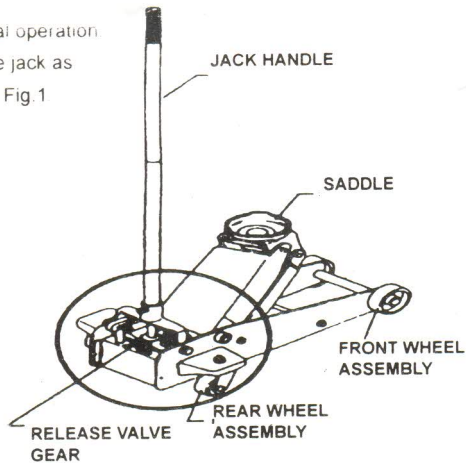
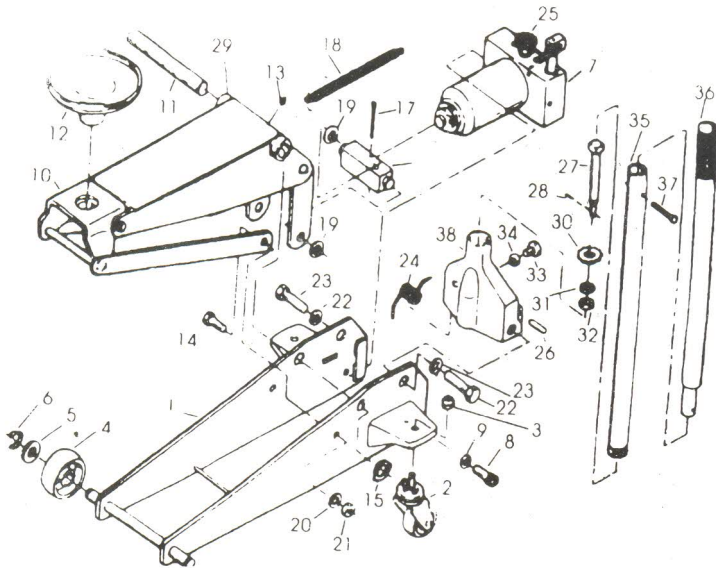

FIG.1

## Main Body assembly



Index No.	Description	Qty	Index No.	Description	Qty
1	Side Plate	2	20	Lock Washer	2
2	Caster Assembly	2	21	Hex Nut	2
3	Lock Nut	2	22	Lock Washer	2
4	Wheel	2	23	Bolt	2
5	Washer	2	24	Torsion Spring	1
6	Retaining Ring	2	25	Release Valve Assembly	1
7	Power Unit Assembly	1	26	Plunger Pin	1
8	Screw	2	27	Gear Shaft	1
9	Lock Washer	2	28	Pin	1
10	Linkage Assembly	1	29	Lifting Arm Assembly	1
11	Shaft Arm	1	30	Release Valve Gear	1
12	Saddle	1	31	Lock Washer	1
13	Grease Fitting	1	32	Hex Nut	1
14	Bolt Link	2	33	Handle Bolt	1
15	Retaining Ring	1	34	Spacer	1
16	Ram	1	35	Handle (lower)	1
17	Pin	1	36	Handle (upper)	1
18	Return Spring	1	37	Screw	1
19	Retaining Ring	2	38	Handle Socket	1

## Power Unit Assembly

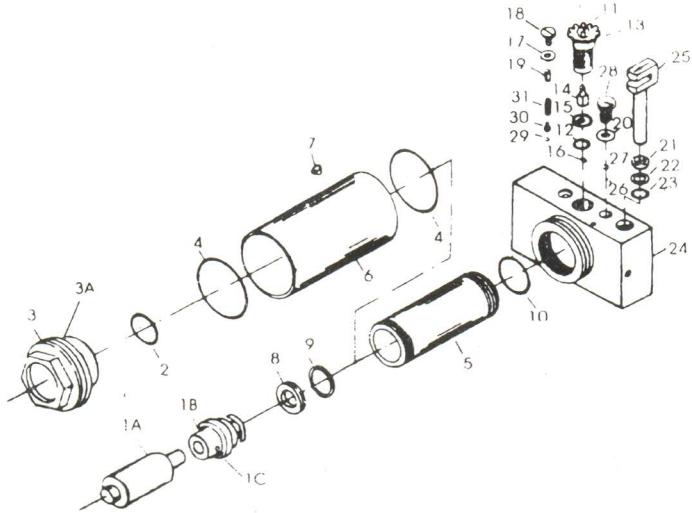

Index No.	Description	Qty	Index No.	Description	Qty
1A	Ram Rod	1	16	Ball	1
1B	Ram Head	1	17	Seal Washer	1
1C	Ram Head Pin	1	18	Plug Screw	1
2	O-Ring	1	19	Overload Valve Screw	1
3	Tank Nut	1	20	Washer	1
4	O-Ring	2	21	Wiper	1
5	Cylinder	1	22	Back-up Ring	1
6	Reservoir	1	23	O-Ring	1
7	Oil fill Plug	1	24	Valve Block	1
8	O-Ring Retaining	1	25	Plunger	1
9	O-Ring	1	26	Ball	1
10	O-Ring	1	27	Ball	1
11	Gear Retaining Nut	1	28	Plug Screw	1
12	O-Ring	1	29	Ball	1
13	Release Valve Assembly	1	30	Plunger	1
14	Actuator	1	31	Spring	1
15	Guide Plate	1		Repair Kit (nor shown)	1

## PROBLEM-SOLVING HINTS

POSSIBLE JACK PROBLEMS						POSSIBLE CAUSES AND SOLUTIONS (Refer to Operation and maintenance procedures for detailed information)
Jack will not lift load	Jack will lift load, but will not hold	Jack will not lower completely	Poor jack lifting Pump feels spongy	Jack will not lift to full height	Handle raises by itself when jack is under load	
x						Release valve not tightly closed. To close or tighten, turn release valve clockwise
x			x	x	x	Air is in hydraulic system. Release air from system.
x	x		x	x		Oil level is low in jack. Add oil as required.
		x				Oil reservoir is over-filled. Drain out some oil. Lubrication of moving parts is necessary.
x	x		x			Power unit is malfunctioning. Replace the power unit